

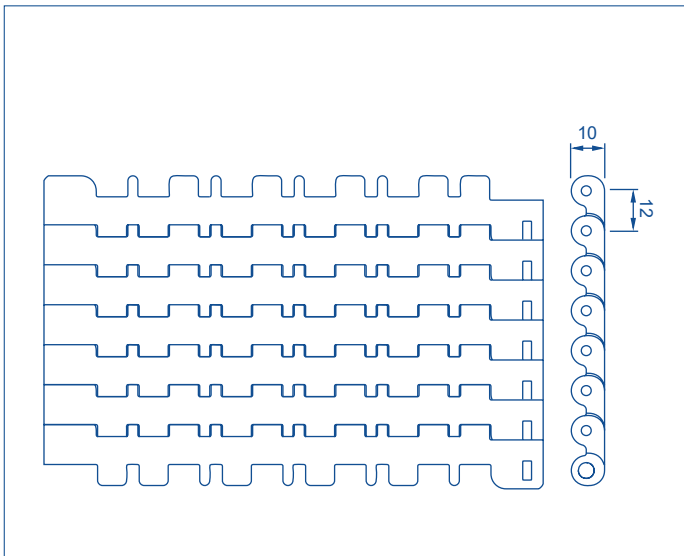





## Series C12 Flat Top



	<b>Belt pitch</b>	12 mm
	<b>Belt width</b>	Multiples of 25 mm
	<b>Rod diameter</b>	4,6 mm
	<b>Drive system</b>	Hinge
	<b>Ø min direct rotation roller</b>	18 mm
	<b>Ø min reverse rotation roller</b>	75 mm

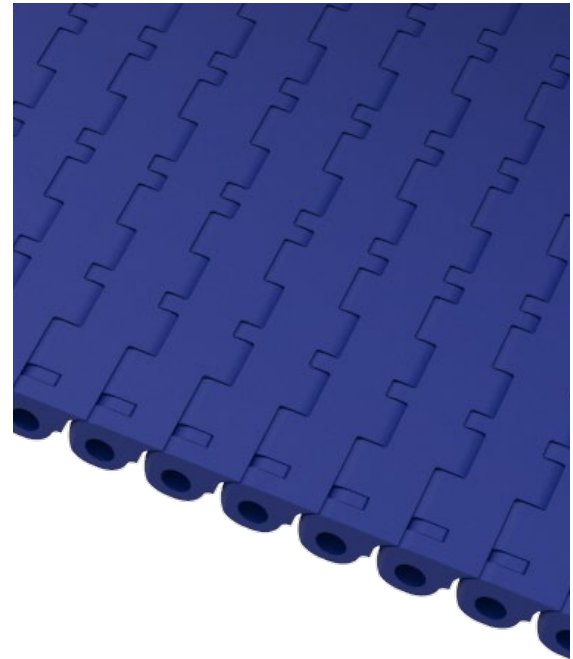

With a 12 mm pitch, it enables to carry out transfers of small product at high speed with minimum turn diameters up to 18 mm, reducing polygonal action. On the other hand, when combined with a bigdiameter sprocket, the turn diameter is close to an almost perfect circumference.

Its open-link structure, with reinforcements shaping a kind of fork, provides a great load capacity. Rods in view together with an extraordinary open surface supply a great easiness for cleaning

Belt surface	Belt material	Rod material	Belt resistance (kg/m)	Belt weight (kg/m <sup>2</sup> )	Temperature limit (C°)	Standard Colours <sup>1</sup>	Open Area + opening dimensions	Belt thickness	Retention system
Flat Top	PP-Polypropylene	PP-Polypropylene	530	6,07	+1 to +104	W - B	0%	10 mm	Cap
	PE-Polyethylene	PE-Polyethylene	300	6,38	-50 to +65	B			
	POM -Acetal	PP-Polypropylene	1450	8,61	+1 to +90	B			
		PE-Polyethylene	1050	8,65	-40 to +65	B			

<sup>1</sup>W = White G = Grey N = Natural B = Blue O = Black

## Accessories **C12** Sprockets

We also have sprockets to be used with motor drum in applications needing a special cleaning or in conveyors in which it is not possible to place the motor in the outside due to problems of space or safety.

N° teeth Z	Ø Pitch	Bore for square shaft		Hub width
		mm	inch	
11	42,59	20	3/4	25
16	61,51	20 - 25	0,8 - 1	25
20	76,70	40	1,5	25
26	99,55	40	1,5	25
31	118,61	40 - 60	1,5 - 2,5	25
40	152,94	40 - 60	1,5 - 2,5	25

\*Consult the technical department for the availability of split sprocket or machined sprocket with different numbers of teeth.

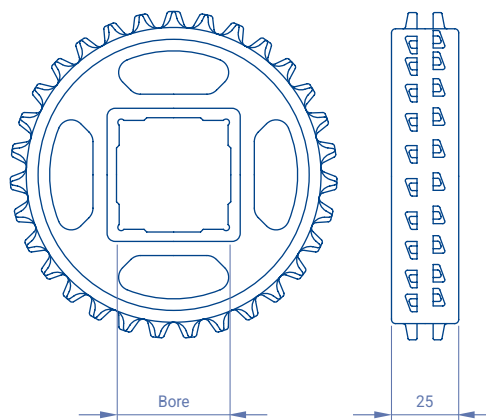

It is manufactured in polypropylene, polyacetal and stainless steel

*\*check availability in other materials*

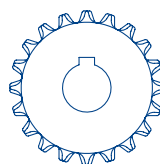

WITH KEYWAY

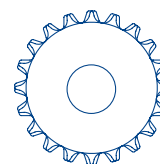

WITHOUT KEYWAY

## Accessories **C12** Flights

Accessories	Height (h)	Materials
Straight flight no cling	50	Polypropylene Polyethylene Acetal

