

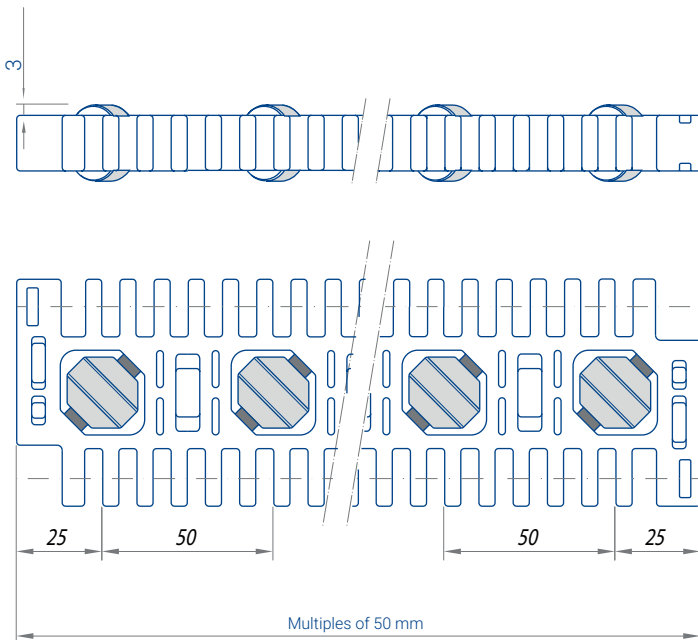



## TECHNICAL DATA SHEET (TDS)

Version [05/2025]

### Series **D50** Roller 45°



 <b>Belt pitch</b>	50 mm
 <b>Belt width</b>	Multiples of 50 mm
 <b>Rod diameter</b>	8 mm
 <b>Drive system</b>	Central
 <b>Ø min direct rotation roller</b>	75 mm
 <b>Ø min reverse rotation roller</b>	150 mm

The D50 Series is a line of modular belts designed to optimize transfers and improve product flow in demanding industrial environments. It stands out for its exclusive design, which maximizes strength, durability, and dimensional stability.

The Roller 0° allows efficient linear movement with the possibility of accumulation and reduced friction; the Roller 45° is designed for 45° transfers, providing greater grip, control, and stability; and the Roller 90° enables smooth side transfers thanks to the orientation of its rollers. In addition, the Flush Grid model without rollers, with a 20% open area, offers excellent mechanical strength for applications requiring ventilation and drainage.

All variants incorporate an 8 mm diameter connecting rod, which reduces wear and maintenance, minimizes stretching, and extends belt service life.

Belt surface	Belt material	Rod material	Belt resistance (kg/m)	Belt weight (kg/m <sup>2</sup> )	Temperature limit (C°)	Standard Colours <sup>1</sup>	Open Area + opening dimensions	Belt thickness	Retention system
<b>Roller 45°</b>	PP-Polypropilene	PA-Polyamide	3640	13,38	+9 a +104	G	17%	16 mm	Tapa

<sup>1</sup>W = White G = Grey N = Natural B = Blue O = Black

#### Special qualities

	Roller diameter	Roller length	Roller contact length with product	Roller height	Roller material
Roller 0°	21.7 mm	19 mm	8.2 mm	3 mm	Acetal + TPE
Roller 90°					

### Food use compliance

#### Declaration of Conformity (EU)

The substances used are included in the Positive Lists of the Legislation of plastic materials in contact with food, Regulation (EU) 10/2011 and its modifications.

#### Food and Drug Administration (FDA)

This regulation describes the polymers that can be safely used to manufacture articles that come into direct contact with food, 21CFR 177.1520 (Olefin polymers) and 21 CFR 177.2470 (Polyoxymethylene copolymer).

# Series D50

## SPROCKETS

We also have sprockets to be used with motor drum in applications needing a special cleaning or in conveyors in which it is not possible to place the motor in the outside due to problems of space or safety.

N° teeth Z	Ø Pitch	Bore for square shaft		Hub width
		mm	inch	
10	161,80	40 - 60	1,5 - 2,5	40
12	193,18	40 - 60	1,5 - 2,5	40
16	256,29	40 - 60	1,5 - 2,5	40

\*Consult the technical department for the availability of split sprocket or mechanized sprocket with different numbers of teeth.

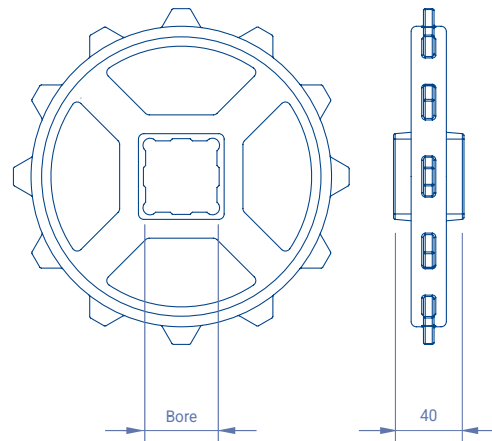

It is manufactured in polypropilene, polyacetal and stainless steel

\*check availability in other materials

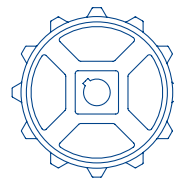

WITH KEYWAY

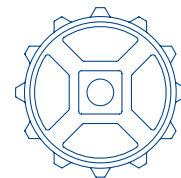

WITHOUT KEYWAY

## RETAINING RINGS

Eurobelt retaining rings are used to secure the central gear on the drive and driven shafts. They are placed on both sides of the central sprocket and are part of the self-guiding system of the modular belts, preventing the sprocket from sliding along the shaft and avoiding lateral displacements of the belt.

Additionally, the effects of temperature cause the belt to expand

or contract.

The rest of the sprockets slide freely along the shaft, allowing them to adapt to the variations and lateral movements of the belt. This ensures that the correct tooth position is maintained at all times.

### CLE RETAINING RING

\*See more in common accessories



AISI 316  
Stainless  
steel

Bore for  
square  
shaft

Screws

20 M5x5

40 M6x6

60 M6x6

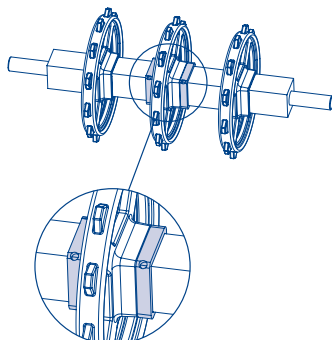

### CLU RETAINING RING

\*See compatibility with diameters in common accessories



Acetal  
High resistance

Working temperature: +60°C / -40°C  
For bore square 40 mm or 1 1/2"

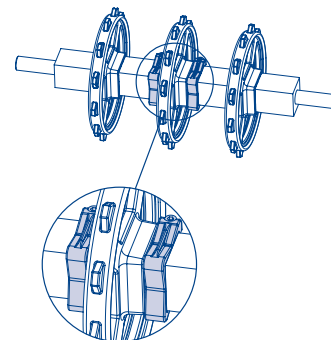

# Series D50

## CONSTRUCTION DATA

### SPROCKETS AND WEARSTRIPS

To calculate the necessary minimum quantity of sprockets for the drive shaft as well as for the idle one, the next formula has been used:

$$\text{Minimum quantity} = \frac{\text{Belt width (mm)}}{150 \text{ mm}}$$

This amount must always be odd.

To calculate the quantity of supports, the weight of the product to be transported must be taken into account.

The distance between supports should not exceed 230 mm in the transport way or 300 mm in the return way.

Belt nominal width (mm)		Minimum quantity of sprockets per shaft	Minimum quantity of wearstrips	
			Transport way	Return way
150	150	1	2	2
200	250	2	2	2
300	450	3	2	2
500	750	5	3	3
800	1050	7	5	3
1100	1350	9	6	4
1400	1650	11	7	5
1700	1950	13	9	6
2000	2250	15	10	7
2300	2550	17	11	8
2600	2850	19	12	9
2900	3150	21	14	10
3200	3450	23	15	11
3500	3750	25	16	12
3800	4050	27	18	13

### SPROCKETS INSTALLATION

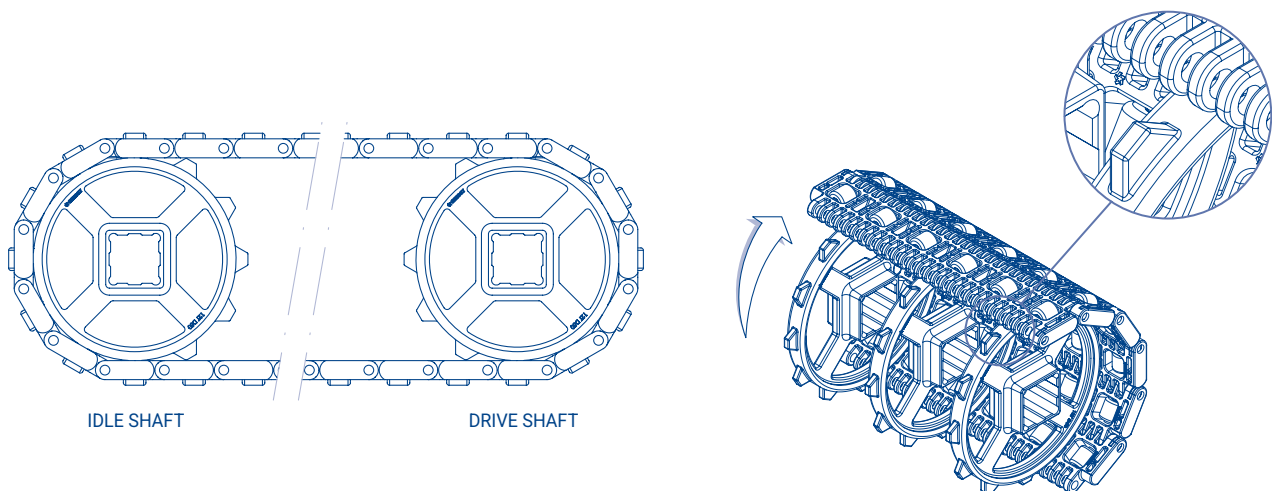

# Series D50

## HORIZONTAL CONVEYOR

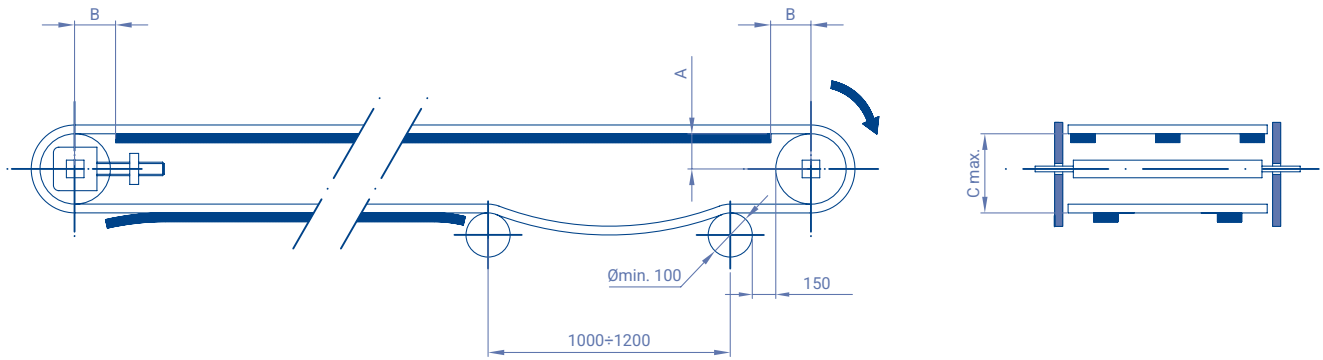

**[A]** Distance between the sliding surface of the belt and the centre of the shaft.

**[B]** Distance between the vertical of the shaft and the beginning of the sliding surface.

**[C]** Distance between the sliding surface of the belt and the support of the return way.

*In the construction of conveyors, the distances appearing in the chart below must be respected according to the belt Series and the size of the sprockets.*

N° of teeth Z	Ø Pitch	A	B max.	C max.
10	161,80	72	76	165
12	193,18	89	78	200
16	256,29	120	80	260