

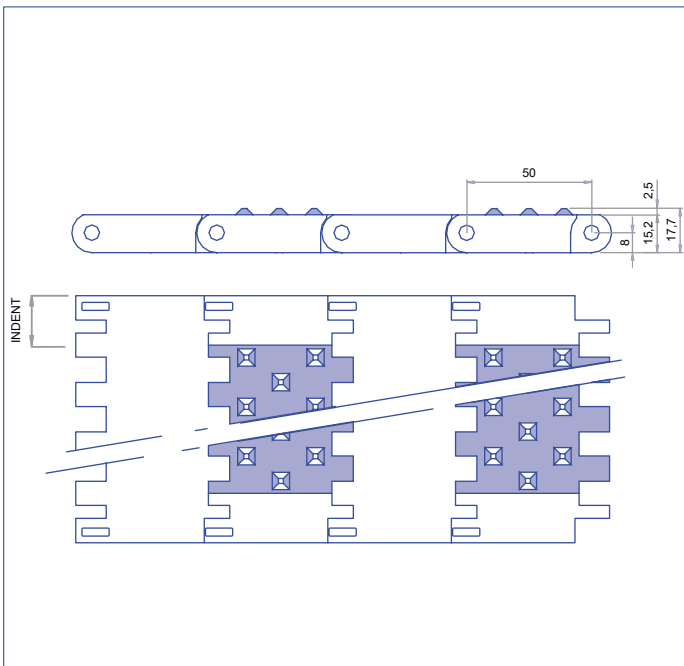





Series E50 Conic Friction



	Belt pitch	50 mm
	Belt width	Multiples of 20 mm
	Rod diameter	6 mm
	Drive system	Hinge
	Ø min direct rotation roller	75 mm
	Ø min reverse rotation roller	150 mm

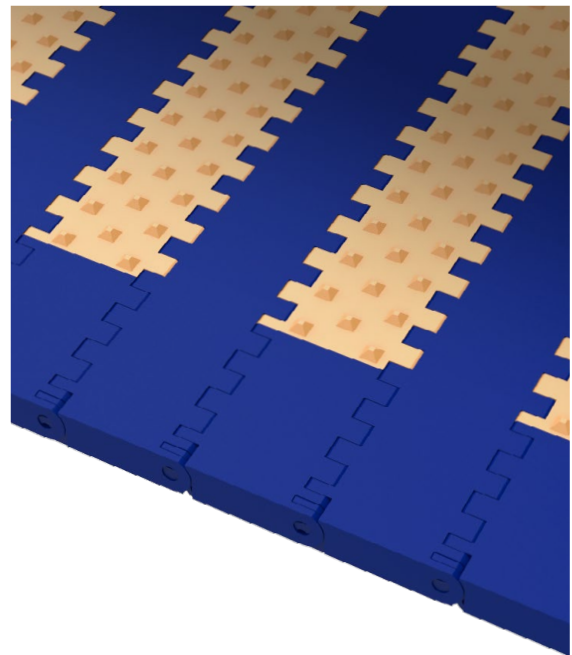

With a 50 mm pitch is the most versatile of all our series due to its wide range of models and accessories.

It can be used in many applications: straight conveyors, elevating and descending conveyors, press machines, palletisers and depalletisers, boiling, glazing, freezing, etc.

It is the most practical solution for most of the conveying applications which do not need very specific requirements. The industries requiring more this series are those of fish, canning, and fruits and vegetables, among others.

Belt surface	Belt material	Rod material	Rubber hardness	Temperature limit (C°)	Standard Colours ¹	Open Area + opening dimensions	Belt thickness	Retention system
Conic Friction	PP-Polypropylene	PP-Polypropylene	Shore A60	+1 to +104	W - G - B	Consult	Consult	Cap
	PE-Polyethylene	PE-Polyethylene	Shore A60	-40 to +65	N - B			

¹W = White G = Grey N = Natural B = Blue O = Black

 Special qualities

	Indent	Spaces between rubber rows
Trian Friction	Multiples of 20 mm	Multiples of 50 mm Minimum of 100 mm

Accessories **E50**

Sprockets

We are also have sprockets to be used with motor drum in applications needing a special cleaning or in conveyors in which it is not possible to place the motor in the outside due to problems of space or safety.

N° teeth Z	Ø Pitch	Bore for square shaft		Hub width
		mm	inch	
6	100	40	1,5	40
8	130,6	40	1,5	40
10	161,8	40 - 60	1,5 - 2,5	40
16	256,2	40 - 60	1,5 - 2,5	60

*Consult the technical department for the availability of split sprocket or machined sprocket with different numbers of teeth.

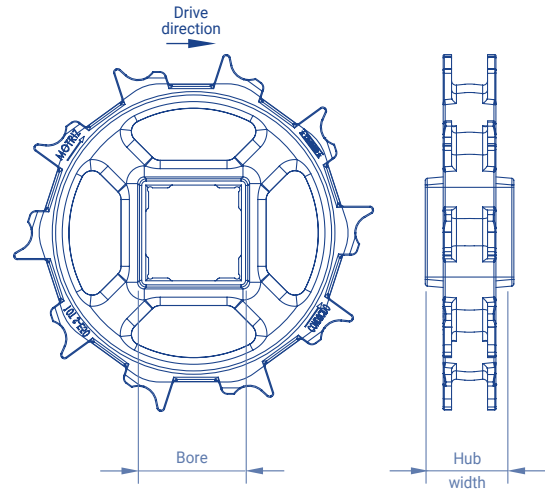

It is manufactured in polypropylene, polyacetal and stainless steel

*check availability in other materials

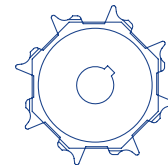

WITH KEYWAY

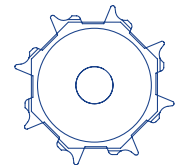

WITHOUT KEYWAY

Accessories **E50**

Flights, Side guards and Rollers

Accessories	Height (h)	Materials
Straight flight (streamline + no cling)	25 - 50 - 75 - 100 - 125 - 150	Polypropylene Polyethylene
Ribbed Flight	75	Polypropylene Polyethylene
Streamline flight	25 - 50 - 75	Polypropylene Polyethylene
No cling flight	25 - 50 - 75 100 - 125 - 150	Polypropylene Polyethylene
Scoop flight	95 - 120	Polypropylene
Bent flight streamline	75	Polypropylene Polyethylene
Bent flight no cling	45 - 70 - 90 115 - 140	Polypropylene Polyethylene
Bent flight (streamline + no cling)	45 - 70 - 90 115 - 140	Polypropylene Polyethylene
Finger plates	50 - 75 - 100	Polypropylene Polyethylene
Hold-down rollers	-	Acetal + Polypropylene Acetal + PBT

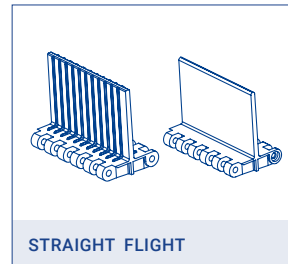

STRAIGHT FLIGHT

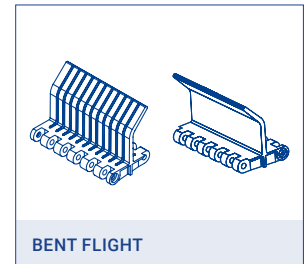

BENT FLIGHT

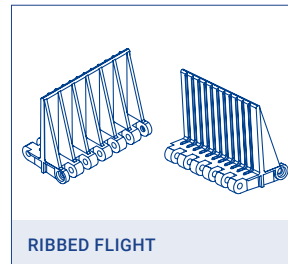

RIBBED FLIGHT

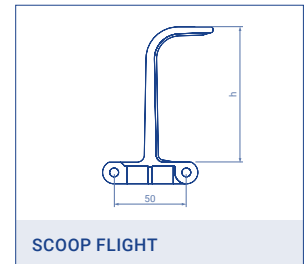

SCOOP FLIGHT

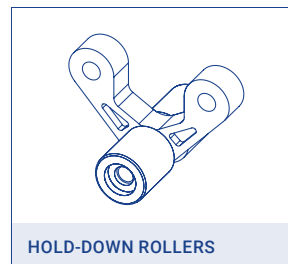

HOLD-DOWN ROLLERS

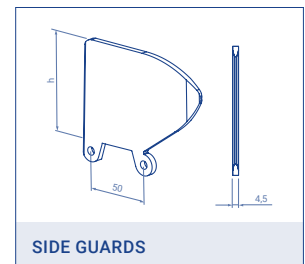

SIDE GUARDS