

## SERIES E20 SLIDING ROLLERS

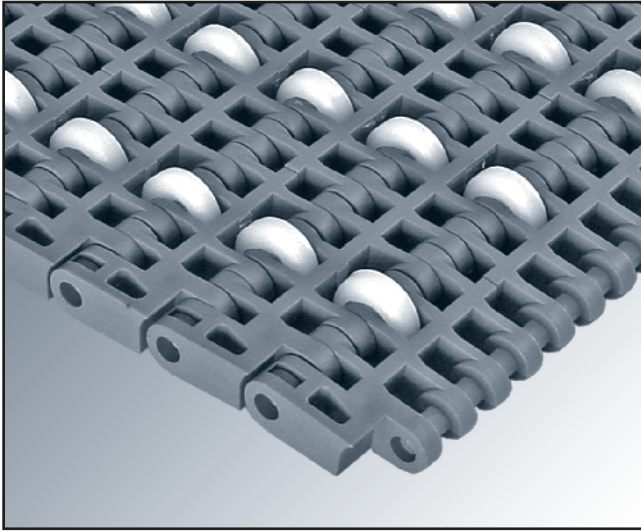

Pitch	20 mm
Surface	Sliding Rollers
Drive system	Central
Belt width	Multiples of 8 mm
Rod diameter	Ø 4.6 mm
Retention system	Cap
Diameter of small roller	Ø 15 mm
Width of small roller	4.9 mm
Material of small roller	Polyacetal
Sliding Rollers pitch	Multiples of 20 mm

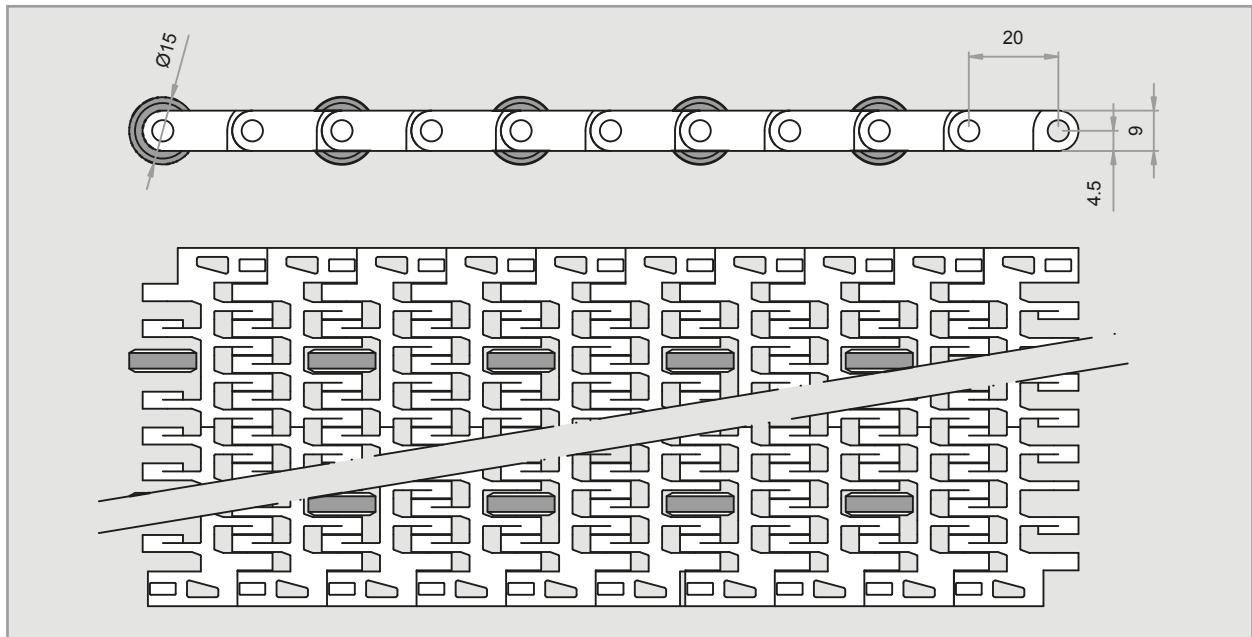

Surface of the belt	Belt standard material	Rod standard material	Belt strength (kg/m)	Temperature range (°C)	Available colours in stock
Flush Grid	PP - Polypropylene	PP - Polypropylene		+1 to +104	[W] - [G]
	PE - Polyethylene	PE - Polyethylene		-50 to +65	[N]
	AC - Polyacetal	PP - Polypropylene		+1 to +90	[B]
		PE - Polyethylene		-40 to +65	[B]

*This conveyor belt has been designed mainly to solve problems of conveyance of boxes, containers, etc.*

*Colours: [W] White - [G] Grey - [B] Blue - [N] Natural - [O] Black. // The materials and colours that are normally in stock are those above indicated. In special cases in which it is needed a belt in a material or colour different from those above mentioned, you should ask directly to EUROBELT.*

## ACCESSORIES [SPROCKETS]

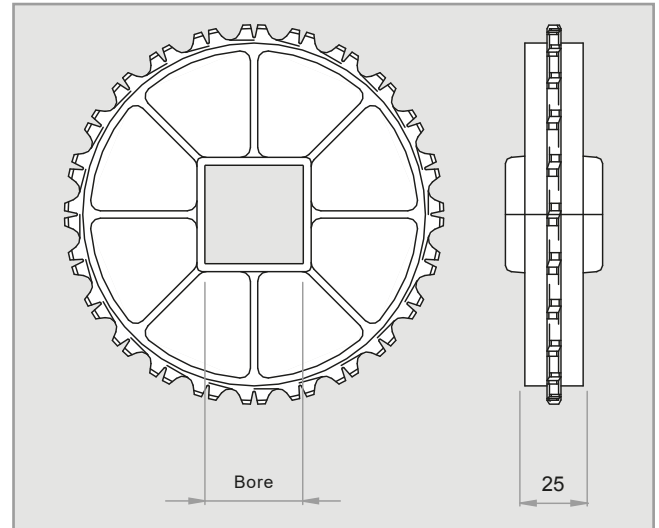

N° of teeth T	Pitch diameter	Bore for square shaft		Hub width	Materials
		mm	inch		
8	52.5	20	¾"	24	Polypropylene Polyacetal Stainless steel
16	102.5	40	1.5"	40	
24	153.5	40 60	1.5"	40	

### SPROCKETS FOR SQUARE SHAFT

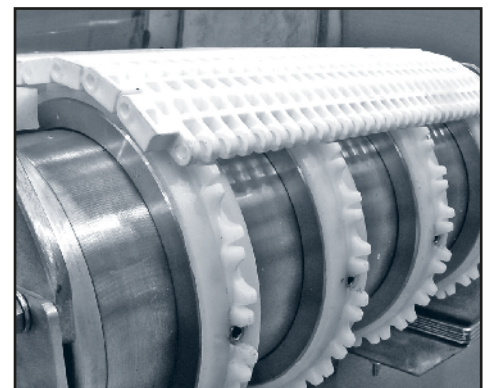
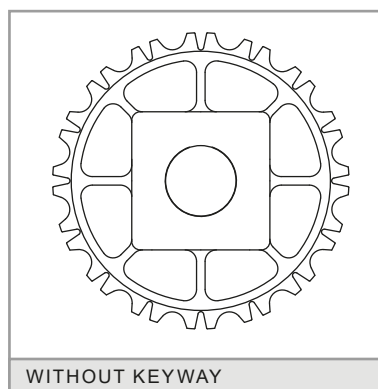
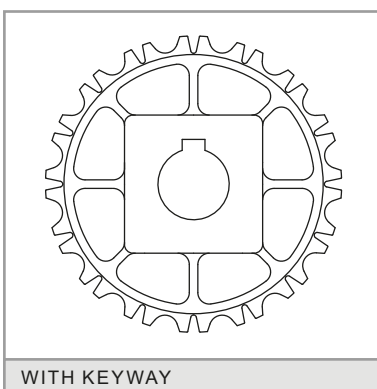

We have plastic sprockets for round shaft with and without keyway. We also have sprockets to be used with motor drum in applications needing a special cleaning or in conveyors in which it is not possible to place the motor in the outside due to problems of space or safety.

## ACCESSORIES [RETAINING RINGS]

### INSTALLATION

These rings are placed at every side of the central sprocket to fasten it to the shaft in order to avoid any lateral movements of the belt.

They are manufactured in AISI 316 stainless steel and they are fixed by means of a set screw stuffed in the ring itself.

One sprocket, duly fixed with 2 retaining rings, should be put in the centre. Then you should place the same quantity of sprockets at every side of the central one but without any fixing, as they will absorb the possible belt expansions and contractions.

The same procedure should be carried out in both shafts.

Bore for square shaft	Screws
20	M 5 x 5
40	M 6 x 6
60	M 6 x 6

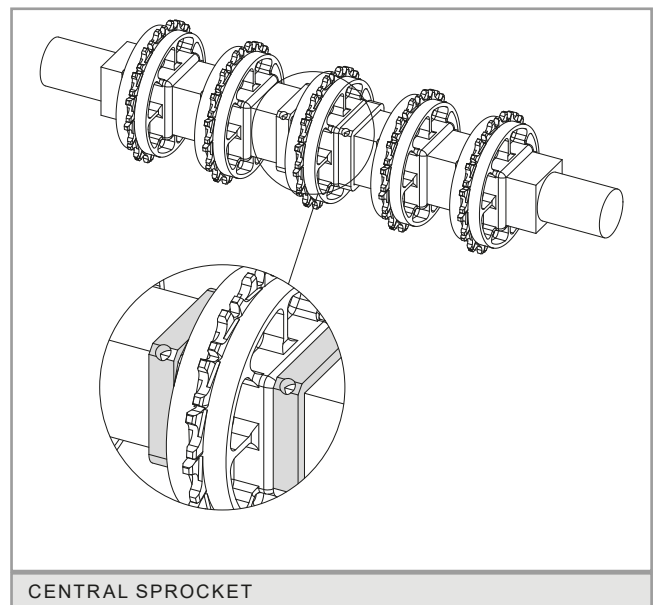
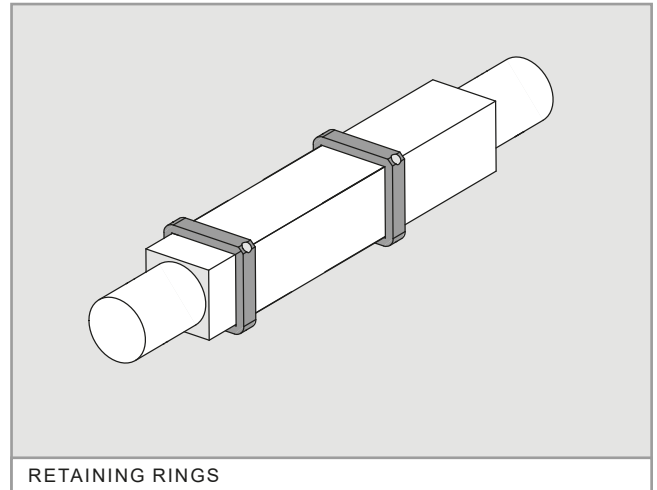

## ACCESSOIRES [CLIP DE FIXATION CLU]

Les clips de fixation Eurobelt CLU garantissent la tenue axiale du Pignon Central des deux arbres: entraînement et renvoi

ACÉTAL. Haute résistance.

Température de travail: +60°C / -40°C

Pour arbre carré de 40 mm ó 1 ½"



CLIP DE FIXATION CLU

Le tapis peut se dilater ou se contracter à cause de la température.

Le système d'entraînement des tapis modulaires nécessite, autant sur l'arbre d'entraînement que sur celui de renvoi, que le pignon central ne se déplace axialement.

Le reste des pignons pourront glisser librement sur l'arbre en s'adaptant aux éventuelles variations du tapis, de sorte que le bon positionnement des dents soit garanti.

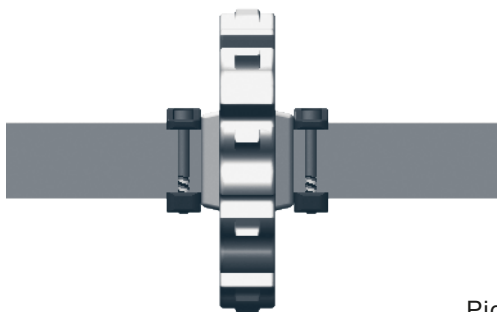

Pignon central



### INSTALLATION FACILE ET RAPIDE

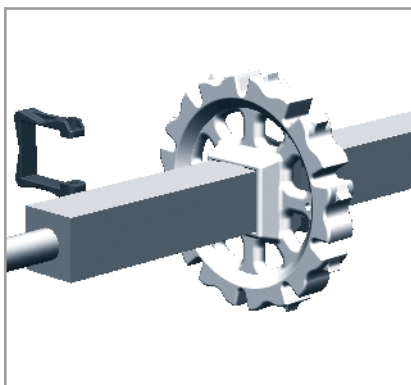

1. Installation directe sans démontage de l'arbre.

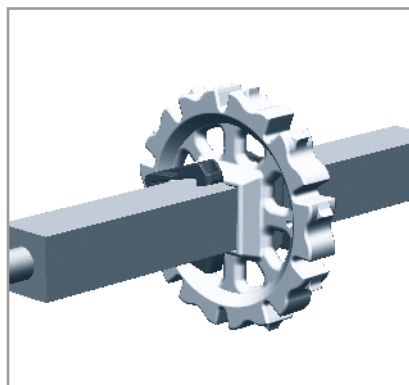

2. Positionnement aisé sur l'arbre en ouvrant le clip.

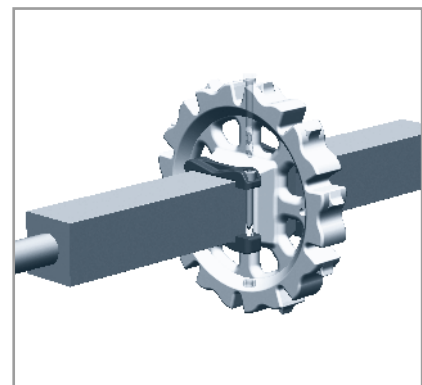

3. Fermeture fiable du clip par une vis et écrou à faible coût.

## CONSTRUCTION DATA [CONVEYOR]

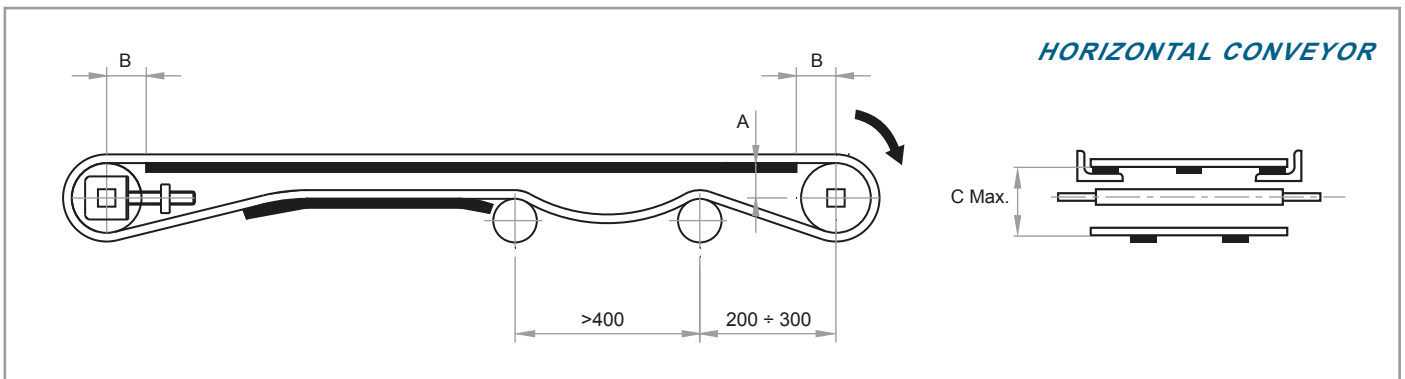
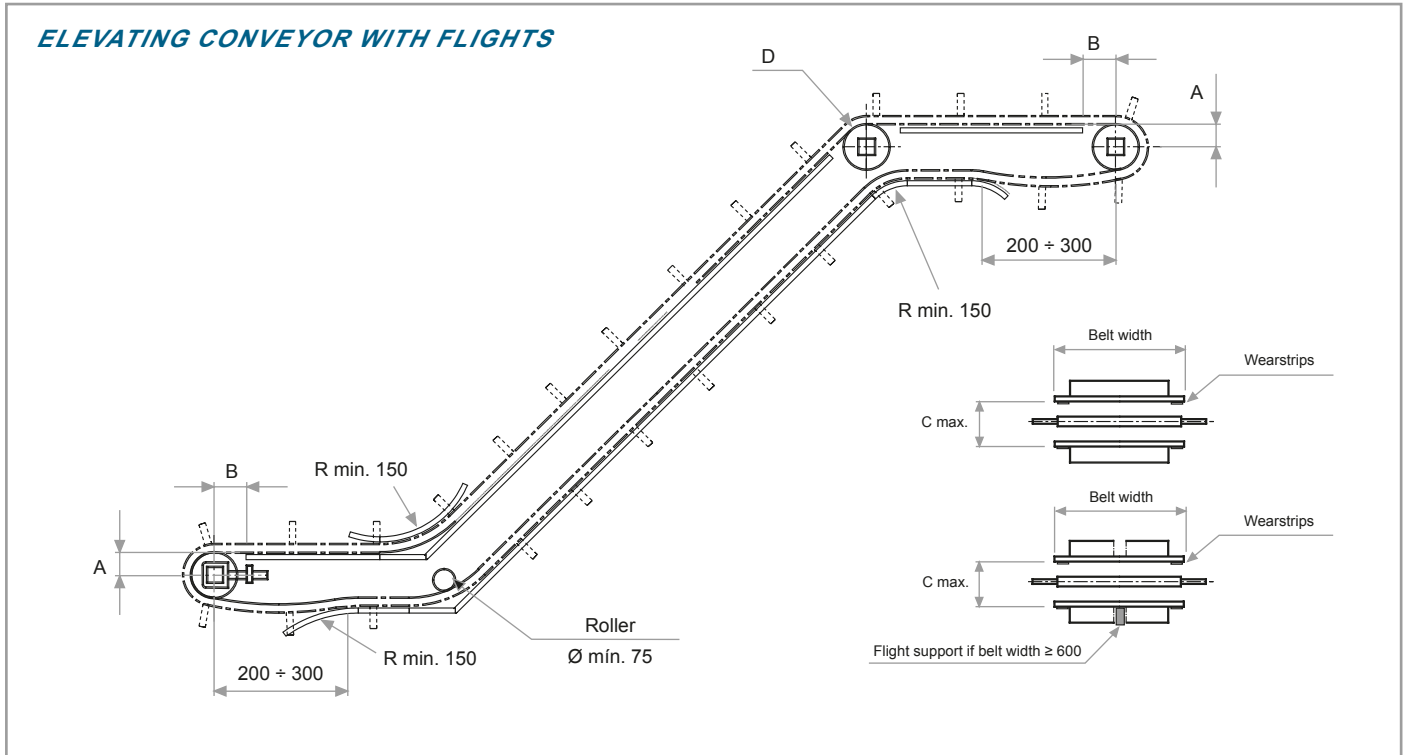

**[A]** Distance between the sliding surface of the belt and the centre of the shaft.

**[B]** Distance between the vertical of the shaft and the beginning of the sliding surface.

**[C]** Distance between the sliding surface of the belt and the support of the return way.

**[D]** If sprockets are used in the inflexion shaft, do not retain the central one.

**[R]** This radius must be as big as allowed by the application in order to minimize the wear (min. 150 mm). For belts with side guards, consult about this radius.

In the construction of conveyors, the distances appearing in the chart below must be respected according to the belt Series and the size of the sprockets.

N° of teeth T	Ø Pitch	A	B max.	C max.
8	52.2	20	28	65
16	102.5	46	50	110
24	153.5	72	65	155

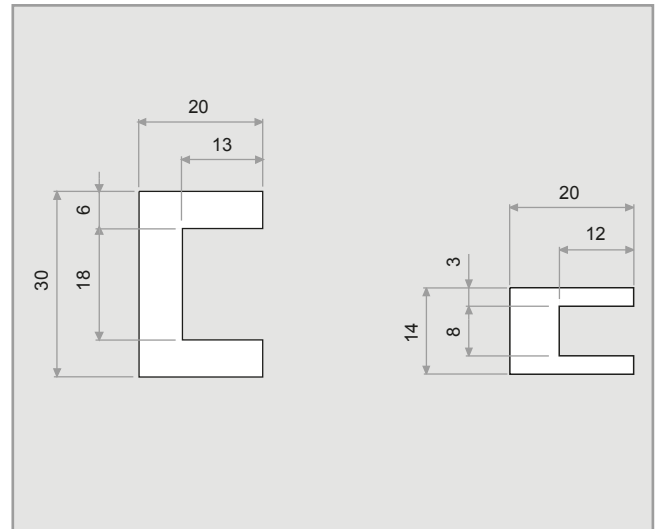
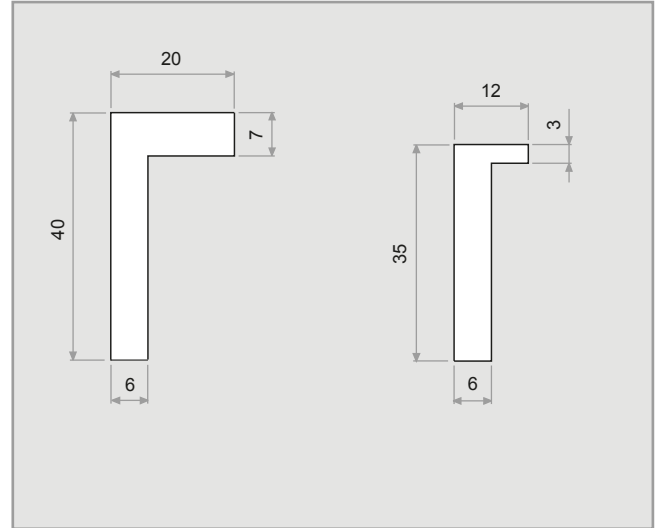

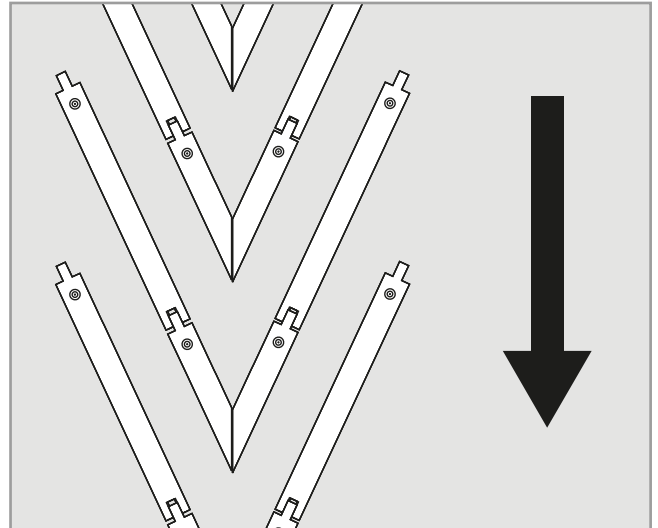
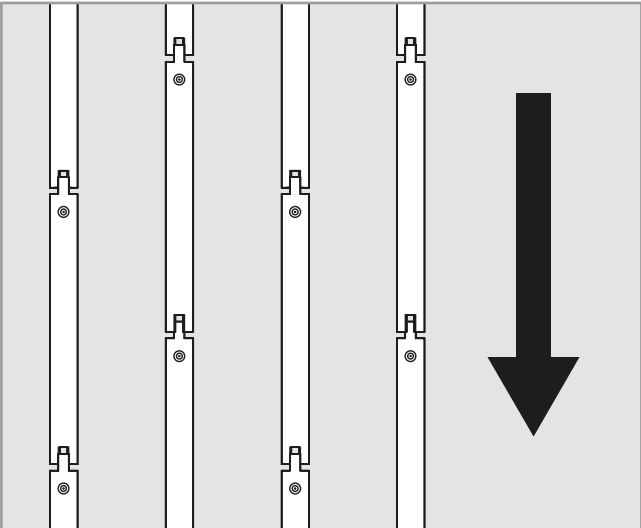
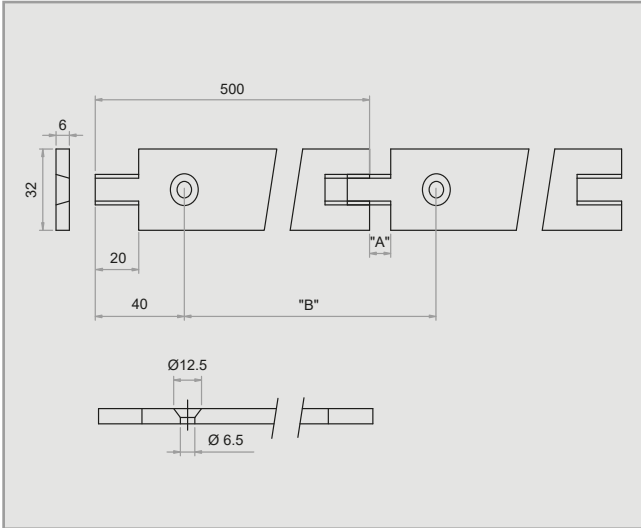



## TABLE OF SPROCKETS AND WEARSTRIPS

Belt nominal width (mm)		Minimum quantity of sprockets per shaft	Minimum quantity of wearstrips	
			Transport way	Return way
32	104	1	2	2
112	216	3	2	2
224	352	5	3	2
360	496	7	4	2
504	632	9	5	3
640	776	11	6	3
784	912	13	7	4
920	1,056	15	8	4
1,064	1,192	17	8	4
1,200	1,336	19	9	5
1,344	1,472	21	10	5
1,480	1,616	23	11	6
1,624	1,752	25	12	6
1,760	1,896	27	13	7
1,904	2,032	29	14	7
2,040	2,176	31	15	8
2,184	2,312	33	16	8
2,320	2,456	35	17	9
2,464	2,592	37	18	9

To calculate the necessary minimum quantity of sprockets for the drive shaft as well as for the idle one, the next formula has been used:

$$\text{Minimum quantity} = \frac{\text{Belt width (mm)}}{70 \text{ mm}}$$

This amount must always be odd.

To calculate the quantity of supports, the weight of the product to be transported must be taken into account.

The distance between supports should not exceed 150 mm in the transport way or 300 mm in the return way.

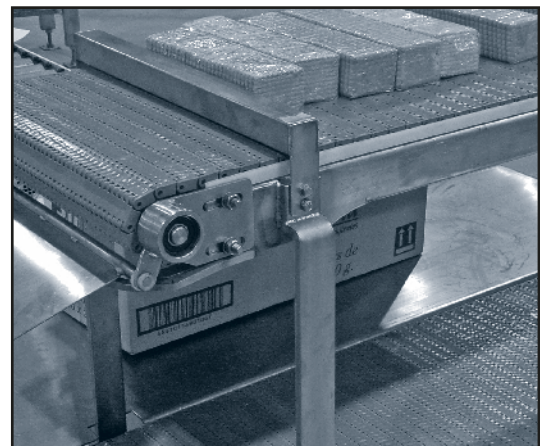



## APPLICATIONS

---

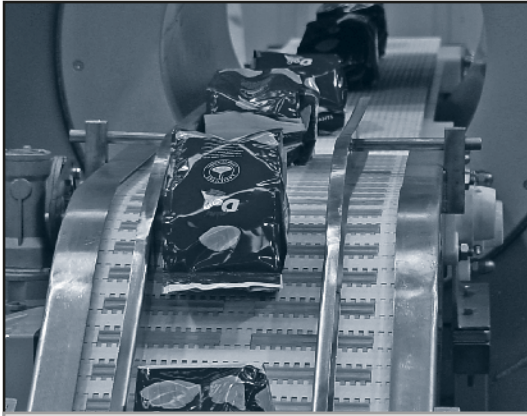

METAL DETECTORS

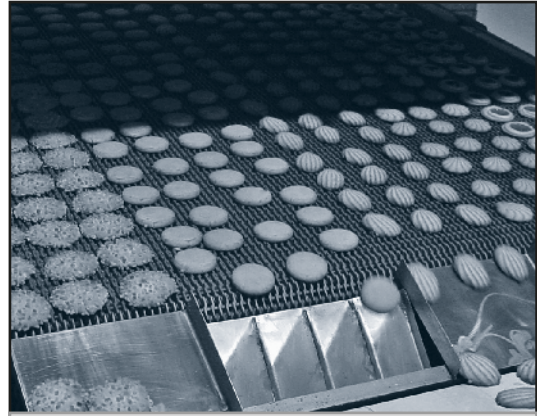

COOLING LINES



ACCUMULATION TABLES



PILE-UP MACHINES



PLASTIC FILM WRAPPING

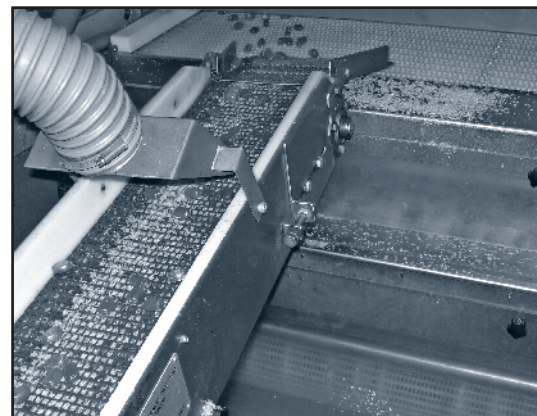

DISTRIBUTORS

## ACCESSOIRES [PROFILS DE SUPPORT]

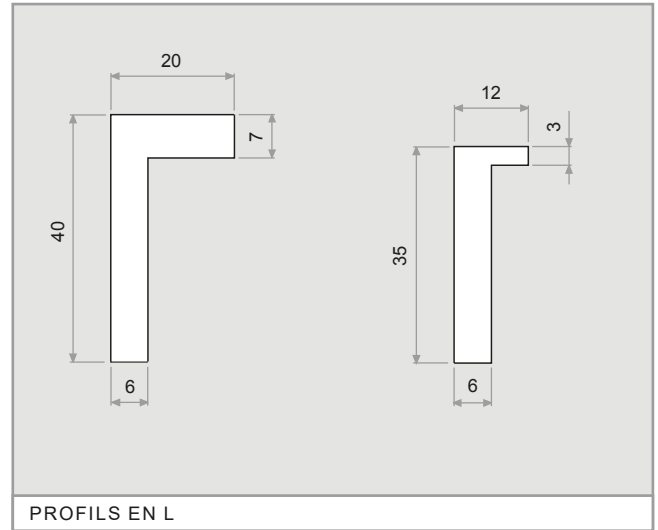

Pour réaliser le support et glissement du tapis, EUROBELT a créé deux types de profils de support avec différentes géométries, mais avec d'identiques fonctions et prestations.

Ces profils avec un coefficient de friction bas, s'intercalent entre le tapis et la structure du convoyeur, réduisant de cette façon l'usure des surfaces de contact et allongeant la durée de vie du tapis.

EUROBELT offre tous les profils de support en polyéthylène spécial avec d'excellentes propriétés glissantes et une excellente ténacité à l'impact.

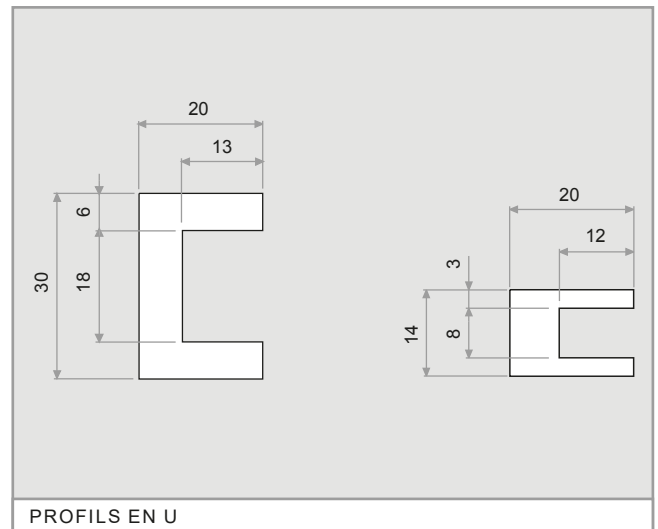

Accessoires	Dimensions	Matériaux
Profils en L	40 x 20 x 2.000	Polyéthylène
	35 x 12 x 2.000	
Profils en U	20 x 30 x 2.000	
	20 x 14 x 2.000	

## ACCESSOIRES [GLISSIÈRES]

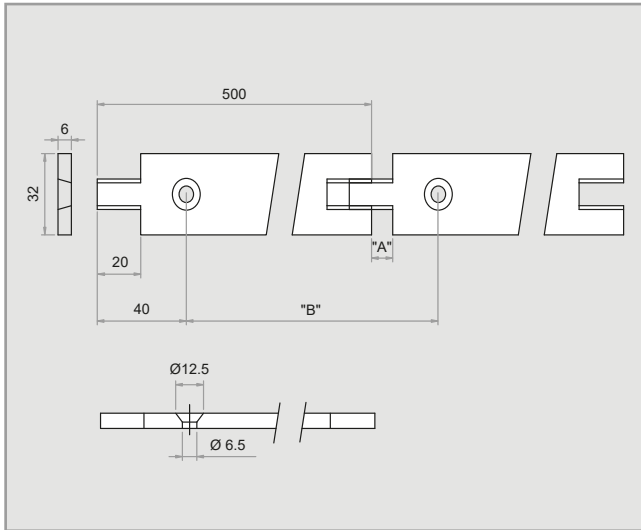

Les glissières plates ont un système de fixation avec des vis plastiques à tête plate, ce qui donne une surface lisse et sans obstacles.

Les dimensions de ces vis sont: M 6 x 25 mm.

Grâce à son dessin en "queue-d'aronde" elles peuvent s'adapter aux possibles contractions et dilatations longitudinales du tapis qui pourraient se produire.

Dimensions	Matériaux
6 x 32 x 500	Polyéthylène Polyéthylène conducteur Acétal

Le montage des bandes de glissement est un facteur important pour la durée de vie d'un tapis transporteur. On devra choisir une configuration adéquate en fonction des besoins de transport. Pour calculer le nombre de supports on devra tenir compte du poids du produit à transporter.

### *DROIT PARALLÈLE*

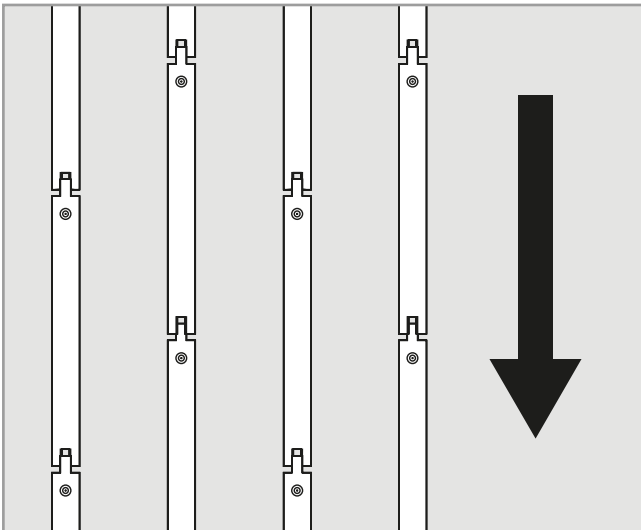

Il consiste à placer les bandes de glissement en parallèle et continu sur la structure du convoyeur tout le long de celui-ci.

De préférence faire de sorte que les jonctions des bandes de glissement soient décalées. Il s'agit probablement du montage le plus simple et économique, mais, en dépendant de la charge à transporter, ils peuvent se produire des usures inégales sur la face inférieure du tapis.

N'est pas conseillé pour les applications avec des charges excessives.

### *CHEVRON OU EN V*

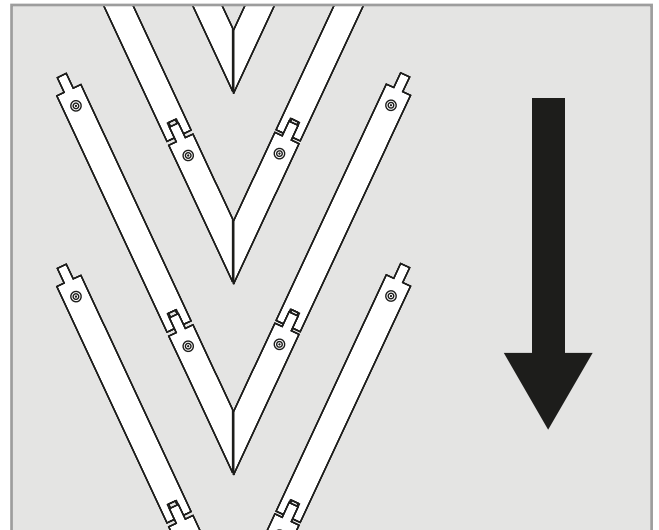

Les bandes de glissement sont placées sur la longueur et largeur du convoyeur selon le dessin ci-dessus.

L'usure possible sera uniformément répartie sur tout le tapis étant donné qu'il est en appui sur toute sa largeur et longueur.

De plus ce montage en angle permet un nettoyage beaucoup plus simple.

Il est recommandé pour des applications avec des charges lourdes ou pour des grandes vitesses.